

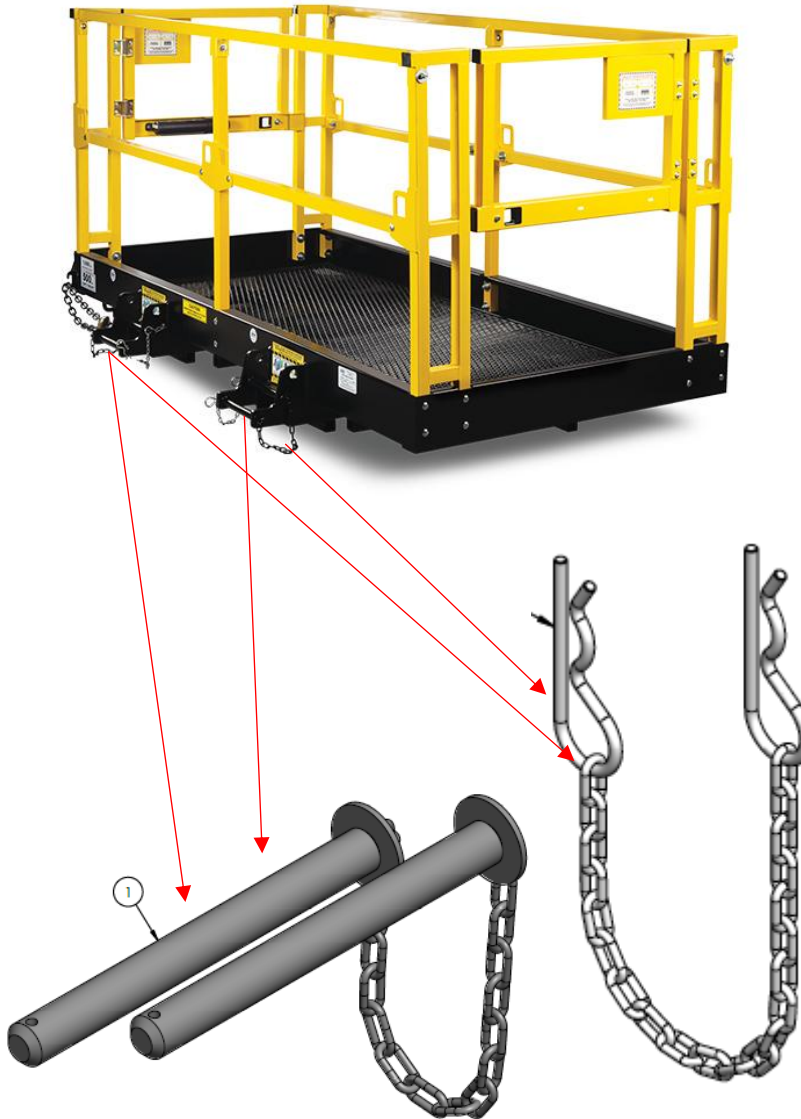

SAFETY WORK PLATFORM ADDENDUM -ABC'S COPY

CUSTOMER NAME _____

INVOICE NUMBER _____



_____ Customer initials to confirm total of
four 1" pins and 4 hairpin cotter pins

PLEASE COLLECT INITIALS FROM CUSTOMER AND RETURN TO SALES COUNTER
AND ATTACH TO INVOICE

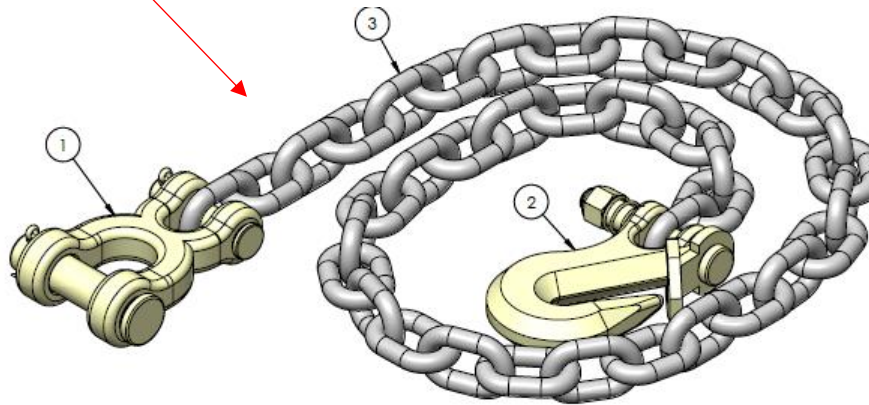

_____ Customer initials to confirm safety chain assembly is in place

PLEASE COLLECT INITIALS FROM CUSTOMER AND RETURN TO SALES COUNTER AND ATTACH TO INVOICE

FORKLIFT

SAFETY WORK PLATFORM

Operator's Manual



BEFORE USE, READ AND UNDERSTAND THE COMPLETE OPERATOR'S MANUAL.

Slip-On-Fork Style			
Model	Size	Capacity	Weight
1204C/G	4' X 4'	1,000 lbs.	350 lbs.
1206C/G	4' X 6'	1,000 lbs.	425 lbs.
1208C/G	4' X 8'	1,000 lbs.	500 lbs.
1210C/G	4' X 9' 8"	1,000 lbs.	575 lbs.

Note: C and G models are the exactly the same except the C Deck assemble is painted Black. The G Deck Assembly is painted Genie Blue and has Genie specified decals.

Platform Descriptions:

Star Safety Work Platforms and Quick-Tach Safety Work Platforms feature a personnel deck with a full perimeter guard rail system. They are designed to elevate personnel and small tools using rough terrain straight-mast or extendable-reach forklifts.

Star Safety Work Platforms have been tested and exceed structural requirements that allow us to rate the platforms at 1000 lbs. load capacity.

DANGER - DO NOT USE WITHOUT INSTALLING RETAINING PINS behind the heel of each fork and securing with hair pins or cotter pins

<p>EMPTY FORK POCKET</p> <p>Stop Pin on some attachments are not removable</p>	<p>1 1/2" TO 2 3/8" THICK FORKS</p> <p>Stop Pin must be in lower hole with using 1 1/2" TO 2 3/8" thick forks</p>	<p>2 1/2" TO 3" THICK FORKS</p> <p>Stop Pin must be upper holes when using 2 1/2" to 3" thick forks</p>
---	--	--

Safety chain(s) must also be used. Wrap chain around a strong part of the fork carriage and secure with locking grab hook.

BEFORE USE, READ AND UNDERSTAND THE COMPLETE OPERATOR'S MANUAL.

If you need clarification or any additional information call your Star dealer or call Star Industries @ 1-800-541-1797 during normal business hours.

Customers Who Bought this product also bought



Lift Hooks -
Lift up to 22,000 lbs
Safely and securely

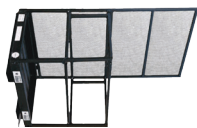

Industrial Work Platforms -
Turn your forklift into an
Aerial work platform



Concrete Hoppers -
Turns Your forklift into
A concrete placer.

Visit www.starindustries.com or call us at 800-541-1797 for more information on these and other great products.

SAFETY STANDARDS AND REQUIREMENTS FOR STAR SAFETY WORK PLATFORMS

All models of Star Safety Work Platforms are designed and built in accordance with and comply with the requirements of ANSI/ITSDF B56.1 2005 Safety Standard for Low Lift and High Lift Trucks and ANSI/ITSDF B56.6 2016 Safety Standard For Rough Terrain Forklift Trucks. They also meet or exceed the requirements of M.O.S.H.A. (state of Michigan), and C.A.L.O.S.H.A. (state of California). Canadian Safety standards vary somewhat by province but generally parallel OSHA allowing Star platforms to conform to their standards as well.

Please note that new ANSI/ITSDF B56.6 2016 Safety Standard states that the forks cannot extend beyond the front of the platform which limits the forks to 48" in length. This standard also states that if the rough terrain forklift truck attachment is equipped with side tilt, the user shall ensure that means for preventing the attachment from tilting laterally is installed and operating properly. Star Safety Platforms feature a full perimeter guardrail system with anchor plates for personnel lanyards built into the guardrails. The Anchor plates have been tested in accordance with and fully comply with the requirements of NSI/ITSDF B56.1 2005 and ANSI/ITSDF B56.6 2016 as well as M.I.O.S.H.A. and C.A.L.O.S.H.A. Note: Star Safety Work Platforms are not designed to be used without full perimeter guardrails.

A question that arises frequently is whether or not controls are required in the platform. Controls in the platform are not required on the style of platforms manufactured by Star Industries and this is substantiated by an OSHA interpretation that specifically addresses this question.

The information provided herein is complete and correct to the best of our knowledge at the time of writing. It is recommended however that this be used only as a guide and that each user do their own investigation of applicable safety standards. Contact should be made with the respective forklift manufacturer for brand and/or model specific requirements or limitations applicable to the use of platforms to elevate personnel.

Prior to Use:

1. Make sure forklift operator has been properly trained, is knowledgeable of forklift model being used, is aware of all relevant safety regulations, and is properly certified.
2. Install complete guardrail system. Do Not Use Platform without full perimeter guardrails installed and secured with bolts and locking nuts.
3. Install optional mast protection screen if moving parts of forklift represent a hazard to personnel on platform. Typically, screens are required on forklifts with an elevating mast. (**Note:** Mast Protection screen is built-in on Industrial Platform Models)
4. Inspect complete platform and guardrail assembly for rust, damage, broken welds, or missing parts before use each day, or at the beginning of each shift. Check that safety decals are installed and legible. If any abnormality is found, discontinue use and contact a Star dealer for a safety inspection. Do not make any modifications to the platform without manufacturer's written approval.

WARRANTY PROCEDURE:

Upon notification, Star Industries will advise if the product will need to be returned to Star Industries for inspection and/or repair, or if the Star Dealer, or other entity, can be authorized to make the inspection/repair at their location, or if circumstances dictate other solutions. Dealer or other entity repairs must have prior written authorization. A "cost of repair" estimate will be required prior to authorization. Reimbursement will be at the current "Star Warranty Labor Rate" and will not include reimbursement for off-site travel. A Warranty Claim Form must be submitted within 45 days of warranty repair authorization to receive credit for repair. A return authorization number must be obtained from Star Industries before a product can be returned for inspection and/or warranty and that number must appear on the return shipping label. Upon inspection, Star Industries will determine if the product is defective and if so, whether it will be repaired or replaced. Repair or replacement is at the discretion of Star Industries. Transportation charges to Star Industries are not covered under the warranty and must be prepaid by dealer or customer unless it is within the first two years of warranty. In which case, if evidence acceptable to Star Industries, is provided that the product is defective and the return is from within the continental United States or Canada, Star will arrange for return shipment at Star Industries expense. Products found to be defective within the initial two year period and returned to Star Industries for repair or replacement will be returned to the dealer or customer freight prepaid providing it is within the continental United States or Canada. Warranted products to be shipped outside the United States or Canada and those warranted after the initial 2 years will be shipped freight collect. Unwarrantable products will be returned freight collect at the request of the dealer or customer, otherwise they will be destroyed.

LIMITATION OF DAMAGES:

Star's obligation under this warranty shall not include costs of installation, duty, taxes or any other charges whatsoever or any liability for direct, indirect, incidental or consequential damages or delay. Star's liability for any and all losses and damage to purchaser resulting from any cause whatsoever, including negligence or breach of form of warranty, express or implied by Star, alleged damage for defective goods, irrespective of whether such defects are discoverable or latent, shall in no event exceed the purchase price of the particular goods. Products repaired or replaced under this warranty are warranted only for the remainder of the original warranty. Any improper use including operation after discovery of defective or worn parts not approved by Star or any alteration or repair by others in such manner as in Star's judgment affects the product materially and adversely shall void this warranty.

THE FOREGOING WARRANTIES ARE EXCLUSIVE AND ARE IN LIEU OF ALL OTHER WARRANTIES (WHETHER WRITTEN, ORAL OR IMPLIED) INCLUDING WARRANTIES OF MERCHANTABILITY AND WARRANTY OF FITNESS FOR A PARTICULAR PURPOSE.

CUSTOMER'S COPY

STAR INDUSTRIES LIMITED WARRANTY

Star Products are warranted to the original purchaser against defective workmanship and/or materials (when properly installed, used, and maintained) for a period as specified below from date of delivery to the customer by an authorized Star Dealer or direct from Star Industries. This warranty does not cover misuse, abuse, normal wear and tear, or accidental damage.

5 year Warranty:	All Star products except as noted below. (Includes HD Auger Drives & most non-hydraulic products)
2 year Warranty:	Medium Duty Auger Drives
1 year Warranty:	Auger Bits and Auger Accessories (excludes auger drives), Crane Forks, Grapples, Angle Broom, Self Dumping Hoppers, Replacement Forks, and Over the Bucket Forks
6 month Warranty:	Concrete Mixers

WARRANTY CLAIM NOTIFICATION:

Product defects should be reported to the Star dealer from whom the product was purchased or to Star Industries in writing promptly after discovery. Preferably photographs showing the defect should also be provided along with a written report of circumstances involved. Warranty claims not made within 30 days after discovery of the defect shall be null and void.

WARRANTY DETERMINATION:

If a warranty claim is found worthy and made within the warranty period we reserve the right at our discretion to repair existing defects or to replace it with the same or current model free of charge or to issue a credit for the reasonable cost of repair or take possession of the equipment and issue reimbursement for the calculated value.

CUSTOMER'S COPY

5. Be certain that forklift is in good operating condition and that the lifting mechanism is operating smoothly throughout its entire lift/reach range both loaded and unloaded.
6. Secure platform to forklift. 'Slip-on-Forks Style' – install the two steel pins in the fork channel tabs and secure with hairpins behind heel of forks. If carriage is equipped with a rotator, deactivate the rotation.
"Quick-Tach Style" – Attach to end of boom after carriage forks are removed. Use only with compatible quick-tach. Make sure all locking pins are installed and engaged. Then secure the safety chains to a strong part of the forklift carriage making sure the chains are not slack and installed as close to a straight horizontal pull as possible.
NOTE – END FORK LOOPS ARE FOR PLATFORM HANDLING ONLY – MUST NOT BE USED WHEN ELEVATING PERSONNEL
7. Establish a method of communication between the forklift operator and personnel to be elevated. Review tasks to be performed and procedures to be followed. Mark area to warn of "work by elevated personnel."
8. Position forklift in desired location making sure the forklift is on firm footing. Avoid operating on a side slope. Be certain the mast or boom is vertical and platform is level before loading personnel – do not operate frame tilt or mast tilt with personnel on platform. Check that the path of platform and boom travel is clear of all hazards such as electrical wires or other obstructions. Make certain forklift, forklift boom, and platform can maintain recommended safe distances from all power lines and electrical components. Do not use if overhead conditions constitute a hazard.

During Use:

1. Entrance gates must be secured before personnel are elevated. Personnel must not climb on or use guardrails as a ladder. Do not use ladders or any other device on the platform to gain additional height.
2. Alert elevated personnel before moving the platform and make positioning adjustments only at their request. Lift and lower personnel smoothly and with caution.
3. Platform must not be used to transport personnel across a job site. Forklift should be moved as close as possible to work area before allowing personnel on platform, then moved only as necessary for final positioning. Before elevating personnel, place transmission in neutral and set parking brake. Always lower platform to ground and allow personnel to exit before repositioning.
4. Forklift operator must remain at controls and stay alert when personnel are on platform.
5. Do not overload the platform or the forklift. The combined weight of the platform and the load (material and personnel - maximum 1000 lbs.), shall not exceed one-third of the capacity of the rough terrain forklift (½ of the capacity for industrial Lift trucks) at the related load center position as indicated on the forklift capacity chart.
6. When equipped always extend outriggers for increased stability.
7. Use only OSHA compliant safety harness and personnel lanyards. Do not attach more than one lanyard to a single

lanyard anchor point.

8. Always follow safety recommendation and procedures of forklift manufacturer as well as comply with all local, state, and federal regulations.
9. End fork loops are for platform handling only and should never be used to elevate personnel.

Inspection of Star Safety Work Platforms

Between Uses

1. Inspect top, sides, and bottom of steel structure for damage or broken welds. If any abnormality is found, discontinue use until it can be determined if structural integrity has been compromised.
2. Inspect steel structure and guardrails for rust. Discontinue use if structural integrity has been compromised, otherwise remove any surface rust and repaint to protect steel.
3. Inspect guardrails for damage and replace if there is any question about loss of strength. Inspect personal lanyard attachment points. Discontinue if any damage to the attachment points is found until repair or replacement can be made. Make sure all bolts are tight and Replace any missing bolts and nuts
4. Inspect gate hinges and latch mechanism for damage or missing parts. Repair as needed before returning to service. Caution, the platform must not be used without the full guardrail system installed and secured with bolts.
5. Inspect fork pockets and attachments pins. Replace any missing or bent pins and make sure there are hairpins there to secure the locking pins.
6. Inspect the deck for damage or deformation. Replace deck if not structurally sound or if any deformation could create a tripping hazard.
7. Check to ensure the below listed decals are in place and legible.
 - a. "Load Capacity" decal
 - b. "Operator Must Remain In Lift Truck" decal
 - c. "Guardrails Must Be In Place And Gates Secured" decal
 - d. "Empty Weight" decal (varies with platform model)
 - e. "OSHA" decal
 - f. "Safety Procedures for Safety Work Platforms" gate decal)
 - g. G series only – Genie warning decal

Mast Protection Screen Installation on Star Safety Work Platforms

Model	Size	Weight
1250	3.5' x 7'	60 lbs.

1. Center screen in a vertical position on the outside of back guard rails. The bottom of the screen should rest on the extended fork pockets.
2. Secure with u-bolts to top rail and mid rail. Insert u-bolts from inside of platform around guardrail and square tubing (one leg of u-bolt through screen) on perimeter of screen. Secure with u-bolt plate and nuts. Each screen requires 4 u-bolts, one on each side at top rail and mid rail.
3. Make sure screen is properly secured before use.

CUSTOMER'S COPY



shown with 1250 Mast Protection Screen